



KROHNE

▶ measure the facts

Pressure measurement

Product overview



Inhalte

4-5	Product selection
6-9	Pressure measurement
10-15	Differential pressure flow measurement
16-21	Hydrostatic pressure level measurement
22-25	Technical data
26-27	Communication technology
28-29	KROHNE Services
30-31	Calibration

KROHNE trademarks:

KROHNE
CalSys
CARGOMASTER
EcoMATE
EGM
KROHNE Care
OPTIBATCH
OPTIBRIDGE
OPTIFLEX
OPTIFLUX
OPTIMASS
OPTIQUAD
OPTISONIC
OPTISOUND
OPTISWIRL
OPTISWITCH
OPTISYS
OPTIWAVE
PipePatrol
WATERFLUX
SENSOFIT
SMARTBASE
SMARTMAC

Trademarks of other owners:

Amphenol
FDT Group
FOUNDATION™ fieldbus
HART
HASTELLOY
Metaglas
PACTware
PROFIBUS®
VARINLINE



measure the facts

technology driven by KROHNE

Letter from the Corporate Management

Dear Customers,

Communication techniques are becoming ever more complex, from the field through to the control level. At the same time the demands for recording physical measured variables such as flow rates, fill levels, temperature, pressure and analysis parameters are constantly growing. The principal requirement in this respect is absolute reliability of the measured values. This means the measuring equipment, even when subjected to disruptive influences such as changing flow profiles or inclusion of gas bubbles, must always deliver reliable values, and above all must guarantee virtually 100 % security against failure.

“Measure the facts” means not only reliable measurement of standard process variables – even under the most difficult process conditions – but also clear and precise process diagnostics right through to the material composition of the medium. Both of these contribute to improved process control and allow remarkable increases in process efficiency and production.

In order to guarantee this for you, more than 400 engineers in the worldwide KROHNE Group are continuously engaged in research into promising technologies for the future, in pursuit of improved measurement and further developments. We are a family-owned enterprise and we take our responsibilities seriously. We have permanent representation in more than 130 countries and employ more than 3,500 people in order to bring you highly innovative products from a single source, and tailor-made technical solutions to your measurement requirements, now and in the future.



Michael Rademacher-Dubbick



Stephan Neuburger



Always the right pressure. Anytime. Any Process.

Pressure is one of the most commonly measured parameters in the process industry. Today, in over 40 % of all flow applications, differential pressure is still the first choice for metering liquids, gas or steam.

Almost 25 % of all liquid level measurement applications are hydrostatic pressure measurements – in case of pressurized vessels almost exclusively differential pressure level measurements.

With the release of the OPTIBAR series, KROHNE is extending its range of process instrumentation to include pressure measurement.

The OPTIBAR series includes a variety of pressure transmitters with ceramic or metal measuring cells, application specific diaphragm seals, primary elements and accessories to match a wide range of industrial process applications.

Product selection list

This table will help you in selecting the right product for your application

	OPTIBAR P 1010	OPTIBAR P 2010	OPTIBAR P 3050	OPTIBAR PC 5060	OPTIBAR PM 5060	OPTIBAR DP 7060	OPTIBAR LC 1010
	Page 6/22	Page 6/16/19/22	Page 6/22	Page 6/9/16/18/23	Page 6/16/18/23	Page 6/10/16/19/ 23-25	Page 17/23
Type							
Gauge pressure	x	x	x	x	x	x	x
Absolute pressure	x	x	x	x	x	-	x*
Differential pressure	-	-	-	-	-	x	-
Measuring range							
Vacuum	x	x	x	x	x	-	x
Up to 40 bar; 580.2 psi	x	x	x	x	x	16 bar; 232.1 psi	100 mH ₂ O
Up to 100 bar; 1450.4 psi	x	-	x	x	x	-	-
Up to 600 bar; 8702.3 psi	x	-	-	-	x	-	-
Up to 1000 bar; 14504 psi	-	-	-	-	x	-	-
Process connection							
Thread	x	x	x	x	x	x	x
Aseptic	-	x	-	x	x	o	-
Flange	-	-	-	x	x	o	x
Front flush	-	x	-	x	x	o	x
Material							
Diaphragm	316L	316L, C-276	316L	99.996% Al ₂ O ₃	316L	316L, C-276	96% Al ₂ O ₃
Pressure port	316L	316L	316L	316L, Duplex, C-276, PVDF	316L	316L, C-276	316L, Titanium grade 2
Output							
4...20 mA, 2-wire	x	x	x	x	x	x	x
HART	-	x	-	x	x	x	x
Profibus	-	-	-	x	x	x	-
FOUNDATION™ Fieldbus	-	-	-	x	x	x	-
Approvals							
SIL	-	-	-	x	x	-	-
Ex	x	x	-	x	x	x	x*
Hygiene	-	x	-	x	x	-	-
Potable water	-	-	-	-	-	-	x*

x = suitable, o = suitable under certain conditions, - = not suitable, * in preparation

Modular product line for all applications

Pressure transmitters



OPTIBAR P 1010
Ultra-compact pressure transmitter with recessed metallic diaphragm up to 600 bar / 8700 psi



OPTIBAR P 2010
Ultra-compact pressure transmitter with flush metallic diaphragm also for hygienic applications



OPTIBAR P 3050
Compact pressure transmitter with recessed metallic diaphragm, optional display and adjustment module



OPTIBAR PC 5060
Process pressure transmitter with ceramic diaphragm for pressure and level measurement



OPTIBAR PM 5060
Process pressure transmitter with metallic diaphragm also for high pressure ranges and hygienic applications



OPTIBAR DP 7060
Differential pressure transmitter for precise relative gauge pressure measurement with high overload resistance

Diaphragm seals

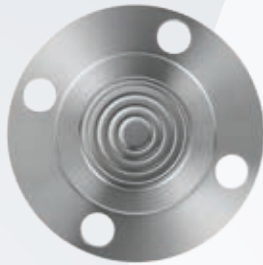

OPTIBAR DS series
Diaphragm seals for temperatures
up to +450 °C / +842 °F
or corrosive mediums



OPTIBAR DS direct
Differential pressure transmitter
with direct mounted single-sided
OPTIBAR DS diaphragm seal



OPTIBAR DS capillary
Differential pressure transmitter
with capillary mounted two-sided
OPTIBAR DS diaphragm seal



OPTIBAR DS direct/capillary
Differential pressure transmitter with
combined direct/capillary mounted
two-sided OPTIBAR DS diaphragm seal

Accessories

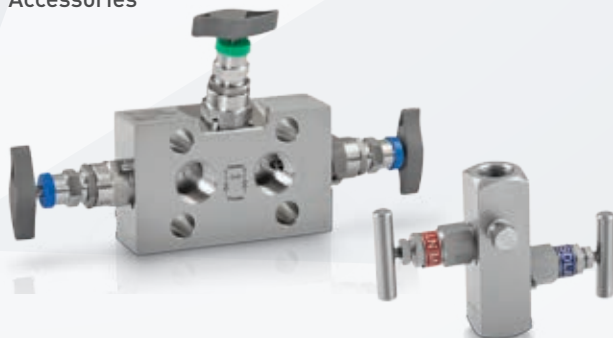

Accessories for safe and easy installation of
pressure transmitters in the process

- Manometer and barstock valves, 3-/5-way valve manifolds, also for steam and high temperature applications
- Flange adapter according to DIN EN and ASME
- Condensate pots for steam applications
- Straight and curved connecting pipes, syphons in U- and circular shapes

Pressure measurement

Process pressure

Industries:

- Oil and gas
- Chemical
- Petrochemical
- Heating, Ventilation and Air Conditioning (HVAC)
- Energy
- Metal and mining
- Food and beverage

Process pressure transmitters are used to measure pressure in pipes or vessels.

OPTIBAR PC, PM and DP transmitters feature a modular concept that meets various requirements of modern process applications:

- Intrinsically safe and explosion proof
- Optional display and adjustment module
- 4...20 mA HART® 7 / HART® SIL 2/3, FOUNDATION™ fieldbus, PROFIBUS® PA
- Plastic, 316L, 316L hygienic, Aluminum

Measuring cells:

- Ceramic (OPTIBAR PC 5060)
- Metallic (OPTIBAR PM 5060)
- DP (OPTIBAR DP 7060)

Capacitive ceramic measuring cells (99.996 % Al₂O₃) with high long-term stability, vacuum and overload resistance are used for all common process applications. The robust ceramic diaphragm with integrated diaphragm breakage detection, covers about 80 % of all pressure applications up to +100 bar / +1450 psi gauge.

Metallic measuring cells (strain gauge or piezoresistive) with fully welded process connection are used for high pressures up to +1000 bar / +14504 psi gauge, aseptic processes, and in combination with OPTIBAR DS diaphragm seals for high temperature or corrosive applications.

Typical applications include:

- Pump dry-run protection and compressor monitoring
- Flue gas ventilation control
- Monitoring processes from low pressure to absolute vacuum
- Overload resistant level and overpressure measurement in batch tanks
- Monitoring of supply pressure in pipelines

Highlights:

- Process pressures -1...+1000 bar / -14...+14504 psi gauge and 0...+600 bar / 0...+8702 psi gauge absolute
- Process temperatures up to +150°C / +302°F without diaphragm seal
- Ceramic or metallic measuring cells
- Quick step response times even with small measuring ranges
- Over 250 thread, flange and aseptic process connections available
- Duplex, HASTELLOY® C-276, PVDF as well as NACE compliant materials
- Use in hazardous areas

OPTIBAR PC 5060 – Process pressure transmitter with ceramic diaphragm for all applications

Extremely high overload resistance

10 bar / 145 psi nominal range can handle 90 bar / 1305 psi pressurespikes without damage or drifts.

99.996 % corrosion resistance

99.996 % Saphire Al_2O_3 ceramic compound is corrosion resistant to almost any medium.

100 % vacuum resistance

Dry cell without fill fluid – therefore temperature-independent resistance to any vacuum conditions.

100 % hydrogen resistance

Ceramic diaphragm is not permeable by atomic hydrogen – special coatings are not necessary.

Robustness

Ceramic is 10 times harder than stainless steel. Abrasion, physical impact, cavitation, water hammers do not have an effect on the sensor.

100 % failure detection

In the unlikely event of a diaphragm breakage, the sensor will immediately detect the failure. Metallic diaphragms cannot give this guarantee.



OPTIBAR PC 5060
Process pressure transmitter with
ceramic diaphragm for pressure and
level measurement

Modular product line for flow measurement

Pressure transmitters



OPTIBAR DP 7060
Differential pressure transmitter for all flow applications, already with integrated absolute pressure measurement

Primary elements



OPTIBAR OP 1000
Standard orifice plates with single bore tapping for cost-effective flow measurement



OPTIBAR OP 1200
Robust split ring orifice plates with interchangeable orifice plate



OPTIBAR PT 2000
Averaging pitot tubes for energy-efficient flow measurement with lowest pressure loss

Calibrated meter runs



OPTIBAR MR 1000
Calibrated meter run with orifice plate
for nominal sizes DN 15...50 / 3/4...2"



OPTIBAR MR 2000
Calibrated meter run with averaging pitot
tube for nominal sizes DN 15...50 / 3/4...2"

Flow computers



OPTIBAR FC 1000
Flow computer for pressure
and temperature compen-
sated gas and steam
measurement and gross/
net energy calculation

Accessories

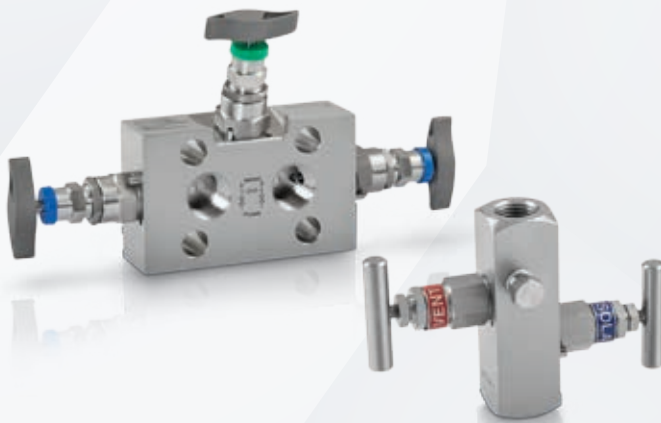

Accessories for safe and easy installation
of pressure transmitters in the process:

- Manometer and barstock valves, 3-/5-way valve manifolds, also for steam and high temperature applications
- Condensate pots for steam applications
- Fittings, seals, blind-plugs, oval flange adapter and gauge snubber

Differential pressure flow measurement

Differential pressure flow measurement

The measuring principle

For over 100 years, the process industry has used the Differential Pressure (DP) flow measurement method to determine the volume or mass of liquids, gases and steam in commercial use.

With DP, pressure is measured at two points across a restriction in the line – for example, a primary element. Using the Bernoulli equation, the difference in pressure between these two points indicates flow velocity and, because the pipe size is known, a volume flow rate can be calculated.

Today, DP is being constantly improved and adapted to meet the requirements of modern processes, and KROHNE is helping to lead the way.

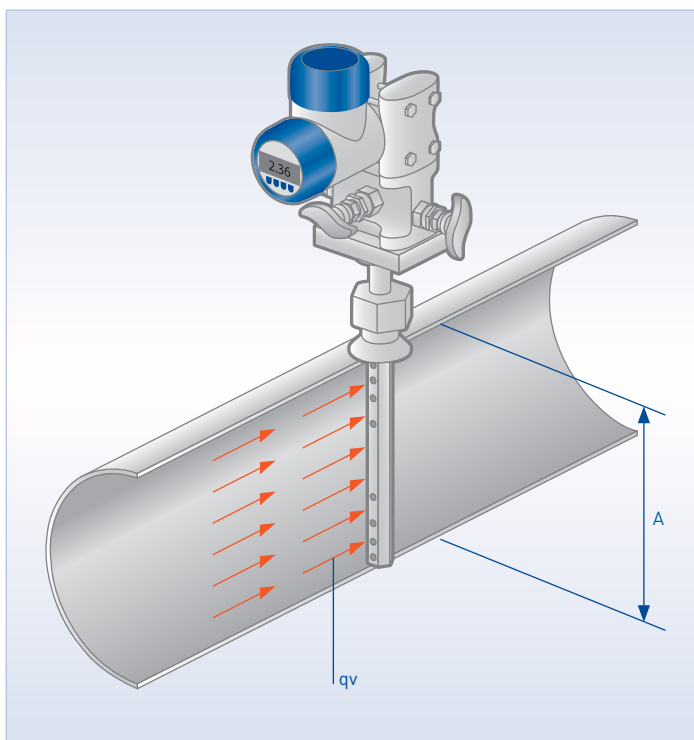

Pitot tube

The pitot tube offers you a simple, cost-efficient flow measurement solution which can be trusted to deliver accurate results over the long term. It is an excellent alternative to orifice plates for:

- Applications that require a low pressure loss
- Retrofitting of existing pipelines with flow measurement
- Line sizes >DN 300/12"
- Low pressure gases

A pitot tube consisting of two chambers is placed in the pipe transversely to the direction of the flow. An upstream chamber faces the flow and a downstream chamber is placed at the back of the probe.

The impact of the medium against the upstream chamber causes an overpressure that adds to the static pressure in the pipe. Depending on its shape, a negative pressure builds up in the downstream chamber. Both pressures are transmitted to a differential pressure transmitter that converts the difference between the two chambers into an output signal.

Flow velocity is calculated using the differential pressure and medium density $v = k \times \sqrt{2 \times \Delta p / \rho}$. Volume flow is calculated from the flow velocity and the crosssection area $qv = v \times A$.

Orifice plates

Orifice plates work by restricting the flow of the liquid, gas or steam being monitored. According to the Bernoulli equation, the flow velocity increases at the restriction, and the static pressure drops. The difference in pressure at the measuring point is a measure for the flow velocity of the medium.

Volume flow is calculated from the flow velocity and the cross-section area: $q_v = v \times A$

The diameter ratio $\beta = d/D$ is determined for each measuring point, allowing each one to be optimised for specific requirements, including short inlet/outlet, low pressure loss and instances of small overall uncertainty.

Orifice plate primary elements are worldwide standardised according to ISO 5167.

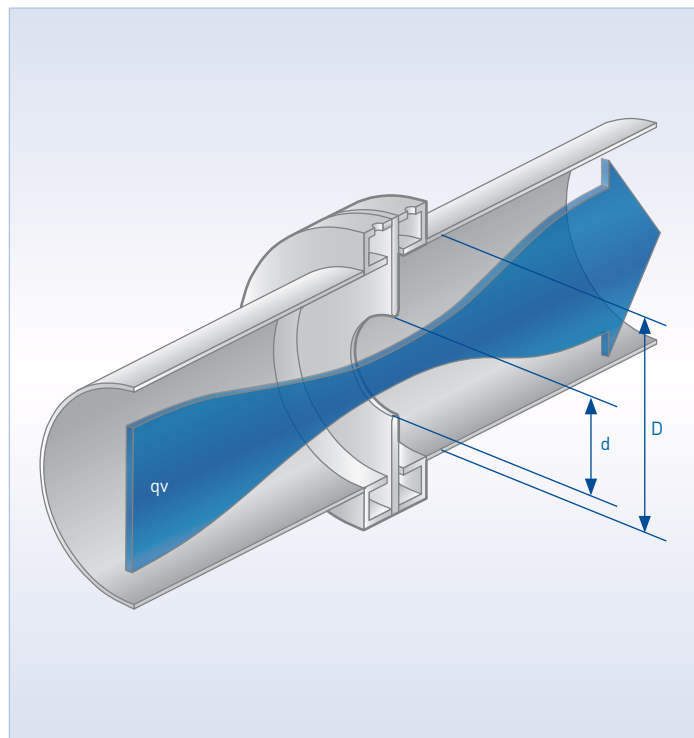

Highlights:

- Worldwide standardised flow measurement principle according to ISO 5167
- All measurement uncertainties under operational conditions are known and can be calculated
- Volume or mass flow measurement of liquids, gases or steam
- Medium temperatures -200...+1000°C / -328...1832°F
- Process pressure up to 420 bar / 6091 psi
- Line sizes from DN25...12000 / 1...470"
- One pressure transmitter for all flow applications, compact or remote version
- Integrated absolute pressure measurement
- Pressure and temperature compensation available as option
- Wet-calibrated meter runs for small line sizes and low measurement uncertainty
- Optimisation of measuring points according to a given specification, e.g. short inlet/outlet, low pressure loss, small overall uncertainty, etc.
- Change of pressure transmitter without process interruption
- No moving parts
- NACE compliant materials
- Compliant to PED 97/23/EC with CE marking
- Use in hazardous areas
- Large choice of materials for corrosive and non-corrosive mediums
- Wet calibration up to DN 3000 / 120" possible
- 4...20 mA HART® 7 / HART® SIL 2/3, FOUNDATION™ fieldbus, PROFIBUS® PA as communication options
- Smallest measuring span 10 mbar / 0.145 psi gauge

OPTIBAR range for differential pressure flow measurement

The OPTIBAR range includes a variety of modular transmitters, application specific diaphragm seals, primary elements, accessories, valves and manifolds.

This offers you the option to buy, from one source, single DP pressure transmitters as well as complete DP flow measuring points, with matched, preconfigured components, (wet) calibrated and ready to install.



Modular design concept

Complete measuring points

KROHNE will provide you with all necessary instruments for your flow measurement point: from primary elements, up to a flow computer for gas, liquid and steam calculations.

For measurement uncertainties due to changing process conditions, the flow computer holds appropriate algorithms for all primary elements. By adding temperature and pressure sensors, density compensation or gross and net energy calculations are also possible.

When commissioning a complete measuring point from us, investment costs like primary element design, component assembly up to pre-parametrisation of the differential pressure transmitter and flow computer are all less. And there are no additional costs for piping, installation and testing at the measuring point.

KROHNE's approach to design also guarantees that up to 70 % of potential leakage points will be eliminated, cutting service and maintenance costs.

Industries:

- Oil and gas
- Chemical
- Petrochemical
- Heating, Ventilation and Air Conditioning (HVAC)
- Energy
- Metal and mining
- Food and beverage

Complete DP flow measuring point for compensated volume/mass flow

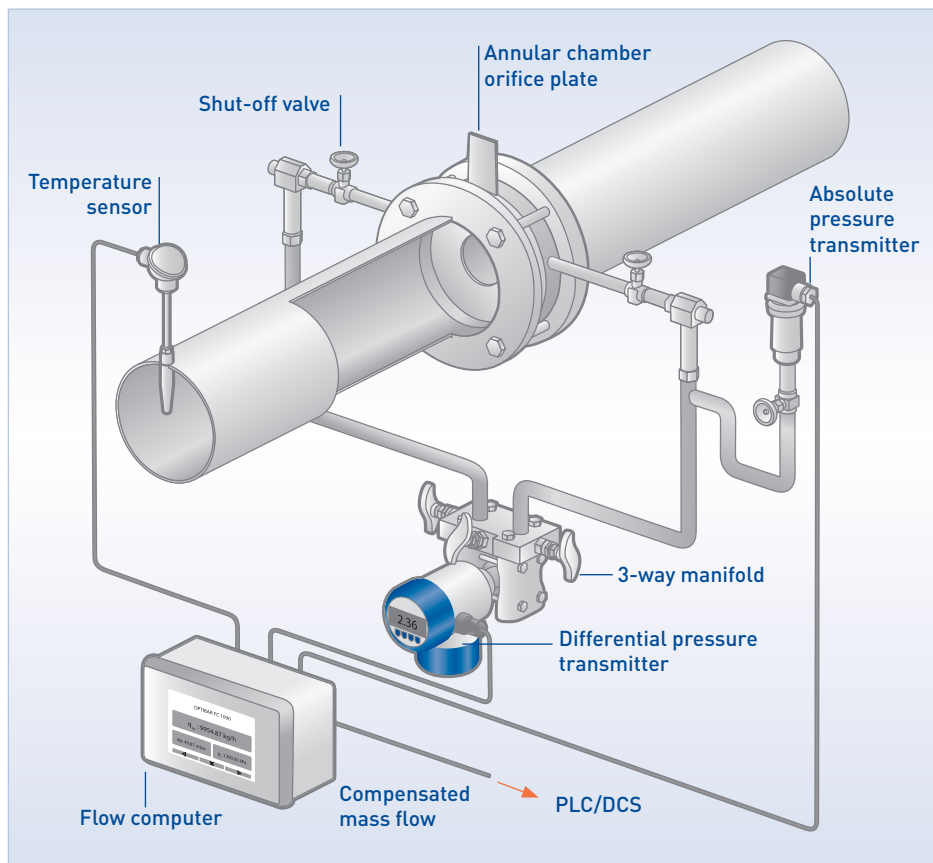

Modular product line for level measurement

Pressure transmitters



OPTIBAR P 2010
Ultra-compact pressure transmitter
with flush metallic diaphragm also
for hygienic applications



OPTIBAR PC 5060
Process pressure transmitter with
ceramic diaphragm for pressure and
level measurement



OPTIBAR PM 5060
Process pressure transmitter with
metallic diaphragm also for high pressure
ranges and hygienic applications



OPTIBAR DP 7060
Differential pressure transmitter
for hydrostatic level measurement
with integrated absolute pressure
measurement

Diaphragm seals

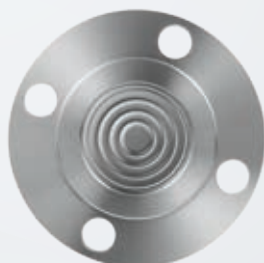

OPTIBAR DS series
Diaphragm seals for temperatures up to +450 °C / +842 °F or corrosive mediums



OPTIBAR DS direct
Differential pressure transmitter with direct mounted single-sided OPTIBAR DS diaphragm seal



OPTIBAR DS capillary
Differential pressure transmitter with capillary mounted two-sided OPTIBAR DS diaphragm seal



OPTIBAR DS direct/capillary
with combined direct/capillary mounted two-sided OPTIBAR DS diaphragm seal

Submersible probes



OPTIBAR LC 1010
Submersible level probe with ceramic diaphragm 22 mm / 1" diameter

Accessories

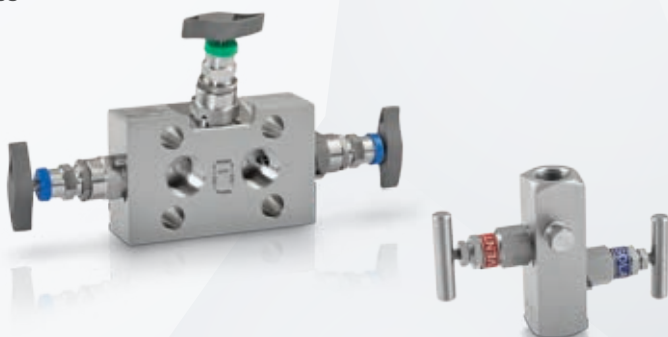

Accessories for safe and easy installation of pressure transmitters in the process:

- Manometer and barstock valves, 3-/5-way valve manifolds, also for steam and high temperature applications
- Flange adapter according to DIN EN and ASME
- Condensate pots for steam applications
- Straight and curved connecting pipes, syphons in U- and circular shapes
- Fittings, seals, blind-plugs, oval flange adapter and gauge snubber

Hydrostatic pressure level measurement

Hydrostatic pressure level measurement in open vessels

The measuring principle

In an open vessel, the contents are connected to the atmosphere. Any change of ambient pressure causes a change of pressure of the fluid in the vessel.

In order to measure the change of the fluid column in the vessel, gauge pressure transmitters or differential pressure transmitters (with open low pressure side) are used to measure hydrostatic pressure in the vessel.

Using Pascal's law, the height a of the liquid level can be calculated from the hydrostatic pressure P , the gravity acceleration g and the liquid density ρ .

$$P_{0\%} = \rho \times g \times a$$

$$P_{100\%} = \rho \times g \times (a+h)$$



OPTIBAR LC 1010 C



OPTIBAR P 2010



OPTIBAR PC 5060



OPTIBAR PM 5060

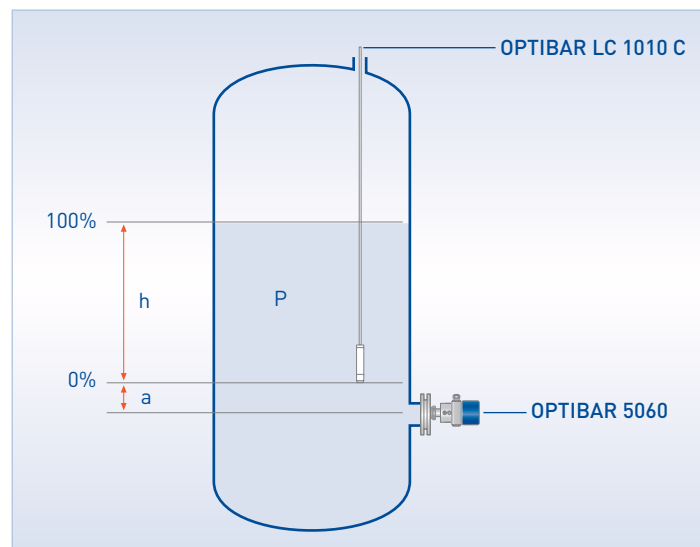

OPTIBAR pressure transmitters for open vessels

You can use OPTIBAR process pressure transmitters to measure the level or density of a liquid in open vessels under atmospheric conditions.

- OPTIBAR PM 5060 and OPTIBAR P 2010 with fully welded metallic diaphragm also for aseptic/hygienic applications
- OPTIBAR PC 5060 with ceramic measuring cell also for abrasive or corrosive liquids, and small measuring ranges of H_2O : 0.25 m / 10"

Hydrostatic pressure level measurement in closed/pressurised vessels

The measuring principle

The pressure in a closed vessel can assume any value. In order to measure the true hydrostatic pressure of the volume in the tank, a differential pressure between the head pressure and the total pressure at the bottom of the vessel needs to be measured at the same time.

Therefore, the high pressure side H is connected to the tank bottom and the low pressure side L is connected to the top. This ensures that the differential pressure applied to the transmitter is proportional to the height of the liquid, regardless of the head pressure inside of the vessel.

By using Pascal's law, the height a of the liquid level can be calculated from the hydrostatic pressure P , the gravity acceleration g , the liquid density ρ , and the distance between the two process connections.

$$P_{0\%} = g \times (a \times \rho_{FL} + (h+c) \times \rho_G - (b+c) \times \rho_{DS})$$

$$P_{100\%} = g \times ((a+h) \times \rho_{FL} + c \times \rho_G - (b+c) \times \rho_{DS})$$

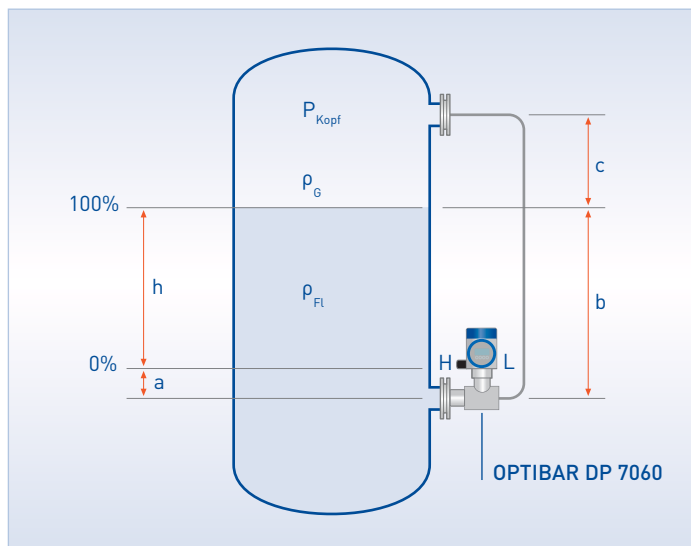

Differential pressure transmitters for closed/pressurised vessels

- The OPTIBAR DP 7060 differential pressure transmitter is ideal for precise level measurement of pressurised containers up to 420 bar / 6091 psi, with integrated head pressure measurement

If the level of a liquid is known, the DP transmitter can also be used to measure the density of the liquid or the position of interface between two liquids of different density.



OPTIBAR DP 7060

Hydrostatic pressure level measurement

Hydrostatic pressure is used to measure level or density of a liquid in a vessel. The OPTIBAR modular product line offers a complete portfolio for hydrostatic level measurement of corrosive and non-corrosive liquids and slurries.

Typical applications include:

- Level measurement of liquids in open and pressurized vessels
- Level measurement in vessels with agitators
- Hygienic level measurement applications
- Steam boiler monitoring
- Level or interface measurement in distillation columns
- Level measurement in water wells, rainwater retaining / overflow basins

The pressure transmitters can be combined with diaphragm seals for high process temperatures up to +450°C / +842°F, corrosive mediums, and can also be equipped with different hygienic and pharmaceutical process connections.

To be used as a simple level measurement solution for wells or tanks, submersible probes are available, perfectly suited for water and wastewater applications.

Highlights:

- Level, density or interface measurement of liquids in vessels
- Medium temperatures up to +450°C / +842°F
- Process pressure up to 420 bar / 6091 psi
- Not affected by fixed or moving inserts/ agitators
- Not affected by process conditions: dust, foam, vapour, agitated or boiling surfaces, or pressure changes
- Large portfolio of process connections suitable for any industry application
- Different hygienic process connections for a hygienic, dead zone-free installation
- Differential pressure transmitter with integrated absolute pressure measurement to measure head pressure
- Measuring range starting at 10 mbar / 0.14 psi
- Interface measurement, also with emulsion layers
- Multiple functions for vessel linearisation integrated in converter
- NACE compliant materials
- Use in hazardous areas
- Smallest measuring span 10 mbar / 0.145 psi gauge
- 4...20 mA HART® 7 / HART® SIL2/3, FOUNDATION™ fieldbus, PROFIBUS® PA as communication options

Industries:





- Oil and gas
- Chemical and petrochemical
- Energy
- Food and beverage
- Mining
- Metal









E05.26.04.27.160LIS1162
+K / 6 B0

21%

	OPTIBAR P 1010 Ultra-compact pressure transmitter with recessed metallic diaphragm up to 600 bar / 8700 psi	Ultra-compact pressure transmitter with flush metallic diaphragm also for hygienic applications	Compact pressure transmitter with recessed metallic diaphragm, optional display and adjustment module
	OPTIBAR P 1010	OPTIBAR P 2010	OPTIBAR P 3050
			
Accuracy (of calibrated span)			
Reference accuracy	<±0.25% FSO	<± 0.25% FSO	<± 0.1%
Long-term stability	≤±0.1% within 1 year	≤±0.1% within 1 year	≤±0.1% within 1 year
Max. turn down	n/a	n/a	10:1
Pressure range			
Sensor	Piezoresistive	Piezoresistive	Piezoresistive
Measuring range	0...0.1 to 0...600 bar; 0...1.4 to 0...8702.3 psi	0.1...40 bar; 1.4...580 psi	0...0.1 to 0...100 bar; 0...1.4 to 0...1450.4 psi
Line pressure	n/a	n/a	n/a
Process connection			
Thread	From G1/4; 1/2"NPT	From G1/2 front flush	From G1/2; 1/2"NPT
Clamp	n/a	From 3/4" ISO 2852	n/a
Flange	n/a	n/a	n/a
Other	n/a	Varivent, SMS DIN 11864-1	n/a
Temperature range			
Process	-40...+125°C; -40...+257°F	-40...+125°C; -40...+257°F	-40...+85°C; -40...+185°F
Ambient	-40...+85°C; -40...+185°F	-40...+85°C; -40...+185°F	-40...+85°C; -40...+185°F
Configuration			
PC tool	n/a	n/a	n/a
Software / HHT	n/a	n/a	n/a
Local	n/a	None - fixed measurement range	With optional display and adjustment module
Material			
Housing	316L	316L	316L
Diaphragm material	316L	316L, Hastelloy® C 276	316L
Fill fluid	Silicon oil	Silicon oil, Food grade oil (FDA listed)	Silicon oil
Communication			
Output	4...20 mA, 0...10 V	4...20 mA, 0...10 V	4...20 mA
Approvals			
Ex	ATEX / IECEx Ex ia 1G / 1D	ATEX / IECEx Ex ia 1G / 1D	-
Functional safety	-	-	-
Other	-	3A	-

Process pressure transmitter with ceramic diaphragm for pressure and level measurement	Process pressure transmitter with metallic diaphragm also for high pressure ranges and hygienic applications	Differential pressure transmitter for hydrostatic level measurement with integrated absolute pressure measurement	Submersible level probe with ceramic diaphragm 22 mm / 1" diameter
OPTIBAR PC 5060	OPTIBAR PM 5060	OPTIBAR DP 7060 C	OPTIBAR LC 1010
			
<± 0.2% <± 0.1% <± 0.05%	<± 0.2% <± 0.1% <± 0.075%	<± 0.065%	<±0.35% FSO
≤±0.1% within 5 years	≤±0.1% within 5 years	<±0.1% within 5 years	<± 0.1% FSO within 1 year
20:1 (100:1)	20:1 (100:1)	100:1	n/a
Ceramic	Piezoresistive, thinfilm	Piezoresistive	Ceramic
0.025...100 bar; 0.4...1450.4 psi	0.4...1000 bar; 5.8...14503.8 psi	10, 30, 100, 500 mbar, 3, 16 bar; 0.15, 0.4, 1.4, 7.2, 43.5, 232 psi	1...100 mH ₂ O
n/a	n/a	40, 160, 420 bar; 580.1, 2320.6, 6091.6 psi	n/a
From G1/2; 1/2"NPT front flush	From G1/2; 1/2"NPT front flush	G1/4; 1/2"NPT	R1"
From 3/4" ISO 2852	From 1 1/2" ISO 2852	With OPTIBAR DS	n/a
From DN25, 1" ASME	From DN25, 1" ASME	With OPTIBAR DS	DN50
Varivent, SMS, DIN 11851, PMC, NEUMO Biocontrol, Neumo Bio-Connect, DIN 11864-1	Varivent, SMS, DIN 11851, PMC, NEUMO Biocontrol, Neumo Bio-Connect, DIN 11864-1	With OPTIBAR DS	Cable: PUR, TPE
-40...+150°C; -40...+302°F	-40...+ 105°C; -40...+221°F	-40...+85°C; -40...+185°F	-40...+80°C; -40...+178°F
-40...+80°C; -40...+176°F	-40...+80°C; -40...+176°F	-40...+80°C; -40...+176°F	-40...+80°C; -40...+178°F
Free DTM, also USB interface	Free DTM, also USB interface	Free DTM, also USB interface	n/a
Yes - generic and DD	Yes - generic and DD	Yes - generic and DD	Yes - generic
With optional display and adjustment module	With optional display and adjustment module	With optional display and adjustment module	n/a
DIN housing in 1- or 2-chamber configuration: 316L, aluminium, 316L (electropolished), plastic (PBT)	DIN housing in 1- or 2-chamber configuration: 316L, aluminium, 316L (electropolished), plastic (PBT)	DIN housing in 1- or 2-chamber configuration: 316L, aluminium, 316L (electropolished), plastic (PBT)	316L
99.996% Al ₂ O ₃ ceramic	316L, Hastelloy® C276	316L, Hastelloy® C276, Monel 400, Tantal, 316L with gold plating	96% Al ₂ O ₃ ceramic
n/a	Silicon oil, Food grade oil, Halocarbon oil	Silicon oil	n/a
4...20 mA, HART®, PA, FF	4...20 mA, HART®, PA, FF	4...20 mA, HART® 7, PA, FF	4...20 mA, HART®
ATEX / IECEx Ex ia, Ex d, Ex d ia	ATEX / IECEx Ex ia, Ex d; Ex d ia	ATEX / IECEx Ex ia, Ex d, Ex d ia	ATEX / IECEx Ex ia 1G
SIL 2	SIL 2	-	-
-	-	-	Drinking water approval [KTW, ACS]

	Averaging pitot tubes for energy-efficient flow measurement with lowest pressure loss	Standard orifice plates with single bore tapping for cost-effective flow measurement	Robust split ring orifice plates with interchangeable orifice plate
	OPTIBAR PT 2000	OPTIBAR OP 1000	OPTIBAR OP 1200
			
Medium	Gas, liquid, steam	Gas, liquid, steam	Gas, liquid, steam
Type	Compact, remote	Compact, remote	Compact, remote
Sizing	KROHNE standard	ISO 5167:2003; ASME MFC-3M 2004; AGA 3; ASME PTC 19.5 2004	ISO 5167:2003; ASME MFC-3M 2004; AGA 3; ASME PTC 19.5 2004
Accuracy	<±1% uncalibrated; <±0.5% calibrated	<±0.6...0.8%	<±0.6...0.8%
Turn down ration (calibrated)	1:5 (1:7)	1:3 (1:6)	1:3 (1:6)
Pressure loss	5...12%	40...95%	40...95%
Max. pressure	PN40	PN40; PN63; PN100	PN40; PN63; PN100
Max. temperature	+450°C; +842°F	+450°C; +842°F	+450°C; +842°F
Line size	DN50...2000; 2...800"	DN50...2000; 2...800"	DN50...2000; 2...800"
Material primary element	316L	316L	316L
Material mounting parts	A105, 316L, 16Mo3	A105, 316L, 16Mo3	A105, 316L, 16Mo3
Optional temperature probe	Yes	No	No
		Differential pressure transmitter for flow applications, already with integrated absolute pressure measurement	
		OPTIBAR DP 7060 C	
			
Accuracy (of calibrated span)			
Reference accuracy DP		<±0.065% up to TD 10:1	
Long-term stability		±0.1% within 5 years	
Total performance		<±0.18%	
Max. turn down		100:1	
Reference accuracy pabs.		<±0.1%	
Pressure range			
Sensor		Piezoresistive	
Measurement range		10, 30, 100, 500 mbar; 3, 16 bar; 0.15, 0.4, 1.4, 7.2, 43.5, 232 psi	
Line pressure		40, 160, 420 bar; 580.1, 2320.6, 6091.6 psi	
Temperature range			
Process		-40...+85°C; -40...+185°F	
Ambient		-40...+80°C; -40...+185°F	
Configuration			
PC Tool		Free DTM, also USB interface	
Software / HHT		Yes - generic and DD	
Local		With optional display and adjustment module	
Material			
Housing		DIN housing in 1- or 2-chamber configuration: 316L, aluminium, 316L (electro-polished), plastic (PBT)	
Diaphragm material		316L, Hastelloy C276, Monel 400, Tantal, Monel 400 with gold plating	
Communication			
Output		4...20 mA, HART® 7, PA, FF	
Approvals			
Ex		ATEX / IECEx Ex ia, Ex d, Ex d ia	

Calibrated meter run with orifice plate for nominal sizes DN 15...50 / 3/4...2"	Calibrated meter run with averaging pitot tube for nominal sizes DN 15...50 / 3/4...2"
OPTIBAR MR 1200	OPTIBAR MR 2000
	
Gas, liquid, steam	Gas, liquid, steam
Compact	Compact
ISO 5167:2003; ASME MFC-3M 2004; AGA 3; ASME PTC 19.5 2004	KROHNE standard
<±0.5...1.5% calibrated	<±0.5...1% calibrated
1:6	1:6
40...95%	5...12%
420 bar; 6091.6 psi	420 bar; 6091.6 psi
+450°C; +842°F	+450°C; +842°F
DN15...50; 3/4...2"	DN15...50; 3/4...2"
A105, 316L	A105, 316L
316L	316L
No	No
Differential pressure transmitter for flow applications, already with integrated absolute pressure measurement	
OPTIBAR DP 7060	
	
<±0.065% up to TD 10:1	
<±0,1% within 5 years	
<±0.18%	
100:1	
<±0.1%	
Piezoresistive	
10, 30, 100, 500 mbar; 3, 16 bar; 0.15, 0.4, 1.4, 7.2, 43.5, 232 psi	
40, 160, 420 bar; 580.1, 2320.6, 6091.6 psi	
-40...+85°C; -40...+185°F	
-40...+80°C; -40...+185°F	
Free DTM, also USB interface	
Yes - generic and DD	
With optional display and adjustment module	
DIN housing in 1- or 2-chamber configuration: 316L, aluminium, 316L (electro-polished), plastic (PBT)	
316L, Hastelloy C276, Monel 400, Tantal, Monel 400 with gold plating	
4...20 mA, HART® 7, PA, FF	
ATEX / IECEx Ex ia, Ex d, Ex d ia	

	Flow computer for pressure and temperature compensated gas and steam measurement and gross/net energy calculation
	OPTIBAR FC 1000
	
Medium	
Water, steam	IAPWS-97
Natural gas	AGA-8 G1/G2 (ISO20765-1) GERG-88 (ISO 12213-3) AGA-NX19
Gases	Ideal gas equation, optional acc. Redlich-Kwong, Redlich-Kwong-Soave, Peng-Robinson
Thermal oil	Therminol66, Shell Thermia B and various other oils by polynomial approximation
Other mediums	Assumption of constant physical properties
Process inputs	
Primary elements	ISO 5167, AGA-3
Volume flow or velocity	Mass flow calculation
Temperature sensor	2x Pt100
Pipe	
Thermal expansion	Acc. AGA-3, VDI-2040, ISO 5167
Interfaces	
Modbus	Modbus RTU and ASCII
Ethernet	Web server, software updates, backup/restore of parameters
FSK modem	Compatible to HART® field devices; digital transfer of measuring values and device parameters
Analog signals	1x Relay (6A; 230 VAC) 2x SPDT (50 mA; 60 VDC)
Display adapter	Link to a remote display module (optional)
User interface	
Display	4.3" TFT color display
Controls	Capacitive touchscreen
Memory	SD-card slot
Inputs	
Flow	0/4...20 mA active/passive, HART®, frequency or pulse inputs
Pressure	0/4...20 mA active/passive
Temperature	3- or 4-wire Pt100, max. length 250 m; 820.2 ft; all inputs are galvanically isolated
Outputs	
Analog outputs	2x 4...20 mA
Switching outputs	1x Relay (6A; 230 VAC) 2x SPDT (50mA; 60 VDC)
Dimensions	Panel housing 135x65x120 mm; 5.28x2.4x4.8 inch: IP20 External display 144x83x18 mm; 6x3.6x0.72 inch: IP65
Power supply	100...240 VAC or 18...36 VDC

Communication technology

Drivers · Protocols · Configuration · Diagnostics

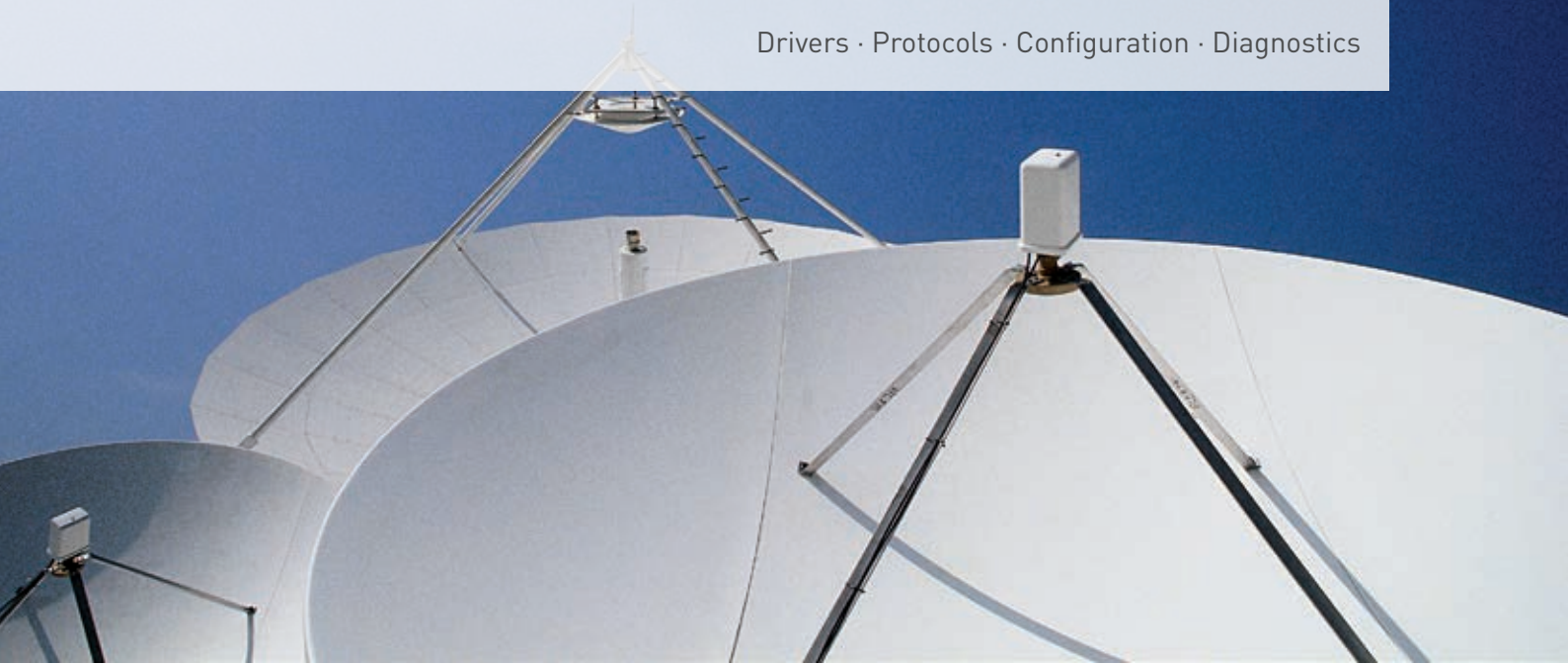

Open for the future

PACTware™ and DTMs

PACTware™ is a manufacturer-independent tool based on FDT technology, providing device configuration and operation. It is free of charge.

DTMs are drivers for FDT-based systems. KROHNE DTMs are also available free of charge, without licence and without any functional restrictions.

KROHNE is committed to making communication convenient. Which is why our field devices communicate reliably with controllers, control systems and PCs, and can also be used for a variety of control and regulating tasks. They meet all of the prerequisites for integration into modern plant asset management systems, based on integration technologies such as DD/EDD and FDT/DTM.

We are a longstanding member of PACTware™ and the FDT Group®. Since 2003, we have made DTMs available for our field devices with HART®, PROFIBUS® or FOUNDATION™ fieldbus interfaces.

For remote monitoring of applications such as water metering, KROHNE has developed a GSM-based solution for online data transmission and logging.

So you will always have the information you need conveniently close to hand.



Clear and fast access to process and device data from any level

KROHNE DTM's are available for many field devices with HART®, FOUNDATION™ fieldbus or PROFIBUS® communication interfaces. They can be integrated into all FDT frame applications.

To assure conformity with the FDT standard, KROHNE DTM's are certified by the FDT Group after certification tests at the KROHNE FDT DTM Test Site, accredited in 2014. In addition, intensive interoperability tests with frames of major host system suppliers are performed.

KROHNE DTM's do not require any licence, providing full functionality free of charge. Next to standard operating features, they provide additional information for commissioning and application engineers.

For example, the DTM for the MFC 400 mass flow converter features clear and configurable diagnostics according to NAMUR recommendations NE 107, and an intuitive layout for fast access to the most used functions. DTM's for level devices are enhanced by fully configurable parameterisation screens for easy commissioning.

Together with PACTware™, KROHNE DTM's come alongside the device on a CD and can also be downloaded from KROHNE Download Centre at www.krohne.com



Configuration of OPTITEMP TT 51 temperature transmitter via PACTware™



Diagnostic data is categorized or can be user-mapped into five categories according to the severity and ease reactions by the operator. Detailed configuration enables predictive maintenance.

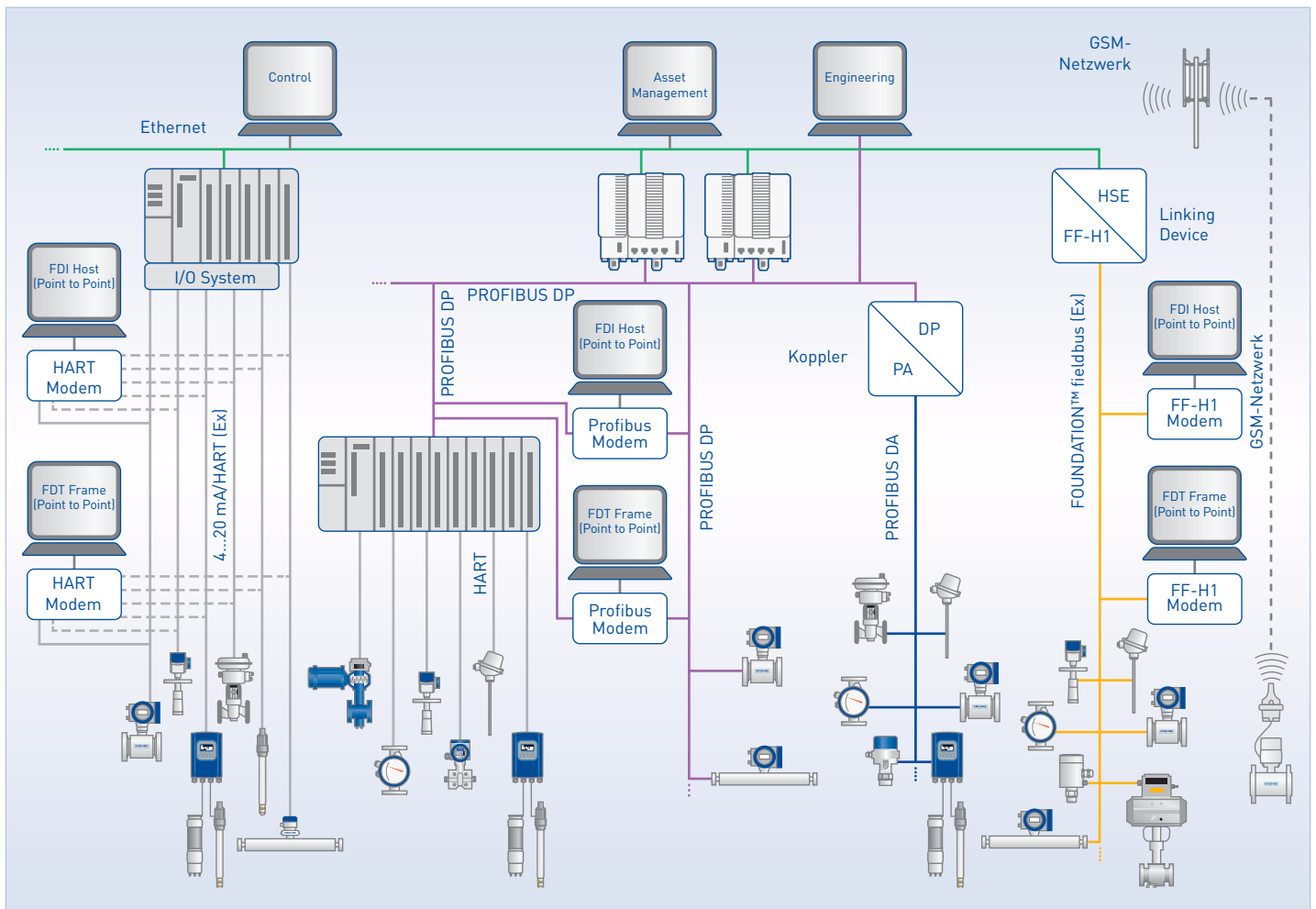

KROHNE services

Engineering services · Online tools and services · Maintenance services · Quality · Training and seminars · Calibration

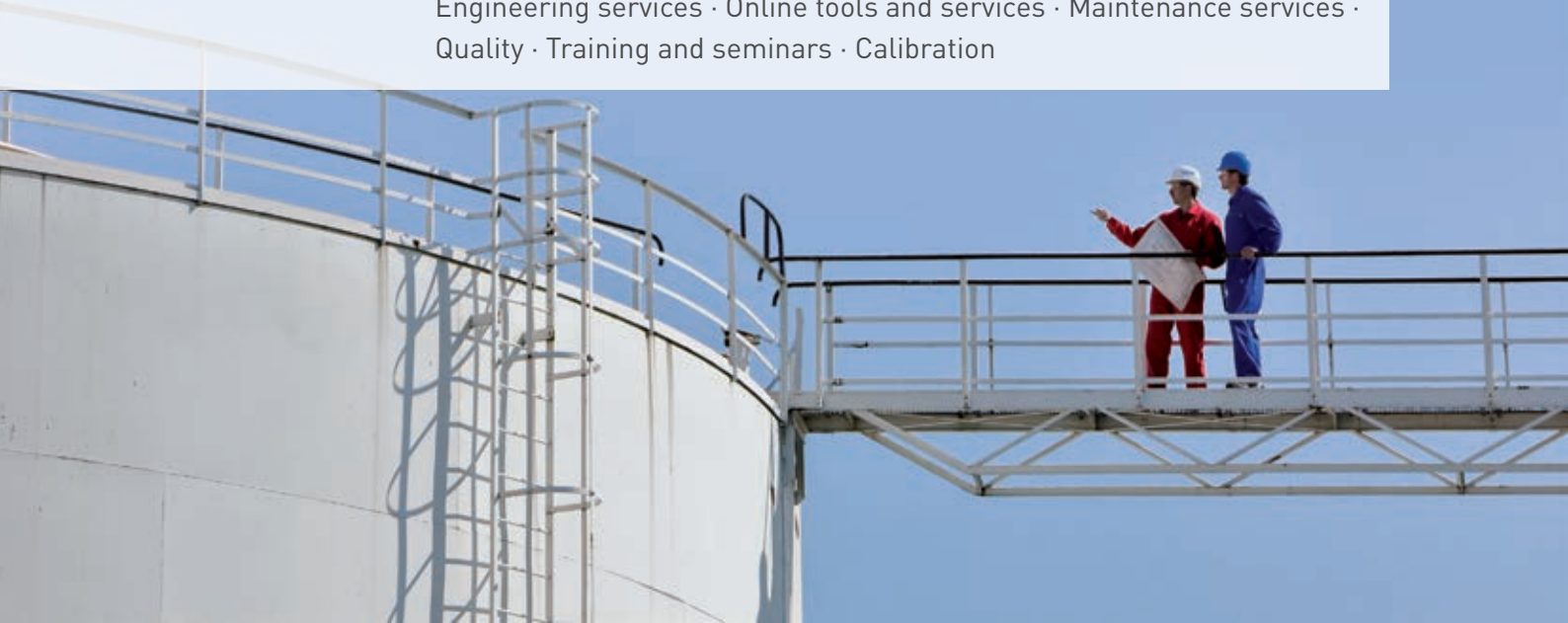

Beyond the highest requirements

For us, service starts at our first contact with you and lasts as long as the life of our systems installed at your plant.

Quality and reliability are key to maintaining the highest service standards. All KROHNE feeder factories are ISO 9001 certified. In fact, long before ISO 9000 existed, KROHNE was already manufacturing to the highest industrial standards. Now certification exists in every factory to demonstrate that we not only fulfil ISO requirements but have passed the ISO certification procedure every three years since the standard was introduced.

But it's not simply a one-way process. We actively encourage companies like yours to participate in our research and development activities. Many of our products that are today considered the pinnacle of excellence were developed in cooperation with our customers.

Engineering services through all project stages

- Project management
- Control and asset management systems in project concept phase
- Basic engineering based on the specification required by the user
- Detail engineering phase
- Commissioning services
- On-site start-up and commissioning
- Product training (on-site)
- Calibration services

Proven quality

Before shipping, every meter is thoroughly inspected. This rigorous programme of specific measurements, tests and factory inspections is called KROHNE proved.

So, if you install and operate any KROHNE product by following our operating instructions correctly, problems shouldn't occur. If they do, we will provide you with all the technical support and service you need.

Choose from maintenance and service contracts tailored to suit all business sizes and needs:

- Spare parts and consumables
- Field service and on-site repair
- Returns
- Workshop repair
- Helpdesk

KROHNE Academy and KROHNE Academy online

The KROHNE Academy is a series of seminars organised in collaboration with leading automation companies aimed at plant engineers, operators and contractors across the process industries. It brings industry experts together to provide an insight into the various technologies, industrial standards and procedures that plant operators can find themselves faced with.

Taking place in various countries, KROHNE Academy seminars address key operating issues, from plant safety to ways of increasing plant efficiency and controlling costs, and show possible solutions. They also provide an ideal opportunity for you to speak to the experts and benefit from their vast application knowledge.

Learn more about KROHNE Academy at www.krohne.com

KROHNE Academy online is a free eLearning platform that contains audio-enhanced, interactive Web Based Trainings. As with its on-site seminars, the online KROHNE academy learning material is vendor-agnostic and not specific to individual products and/or industries. The main focus of each course is on a measurement technology such as Variable Area, Vortex, Ultrasonic or Mass flow or to a more general topic such as the basics of gas measurement or pipeline leak detection.

Register now for free and start your training at <http://academy-online.krohne.com>

Please check www.krohne.com for your local service contact.

Additional online services:

(Find them at www.krohne.com)

- **Configure It**
Configure It is a highly advanced online configuration tool for standard devices offering free 2D/3D CAD data of KROHNE flow devices for planning engineers. It enables you to configure any KROHNE product to handle your application in a few simple steps.
- **KROVASYS 4**
Selection and calculation tool for variable area flowmeters.
- **Planning tool for water & wastewater industry**
The planning tool for wastewater treatment plants as well as water and wastewater applications for generating tender documents covering flow, level, analysis, pressure and temperature.
- **PiCK**
Get any information related to your KROHNE product from our dedicated online resource PiCK. Just enter your serial number, and key material like manuals, Quick Starts and calibration documents is at your fingertips.

Calibration from KROHNE: Certainty you can count on

Calibration is one of KROHNE's core areas of expertise. If you buy a KROHNE product, you will get a measuring device that performs most accurate with low uncertainty under real process conditions.

To achieve this, we operate more than 120 calibration facilities for volume flow, mass flow, level, temperature, density and pressure to (wet-)calibrate any device we manufacture. For example, every flowmeter is wet-calibrated using water or air as standard before leaving our facilities.

We can also provide customer specific calibration such as:

- Carry out multipoint calibrations
- Vary different parameters such as temperatures, viscosities, pressures etc.
- Use the actual medium or similar
- Build or emulate customer-specific flow geometries
- Use piping provided by the customer

For calibration we only use direct comparison of measurands (e.g. we calibrate our Coriolis mass flowmeters with a gravimetric weighing system). Our calibration rigs are the most accurate used in measuring device production worldwide: the accuracy of the reference is usually 5 to 10 times better than that of the meter under test.

The world's most precise volumetric calibration rig for flowmeters up to DN 3000/120"

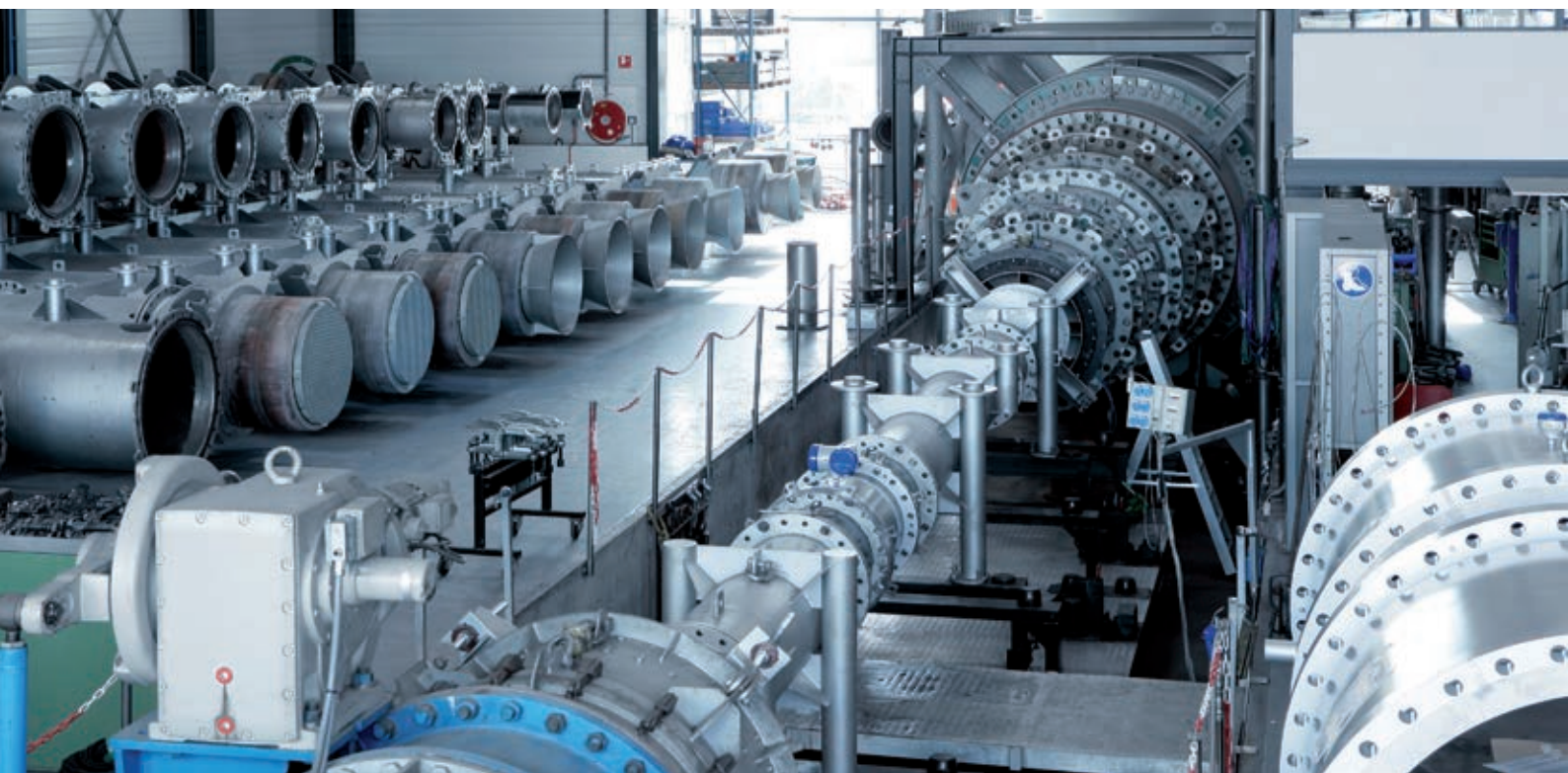

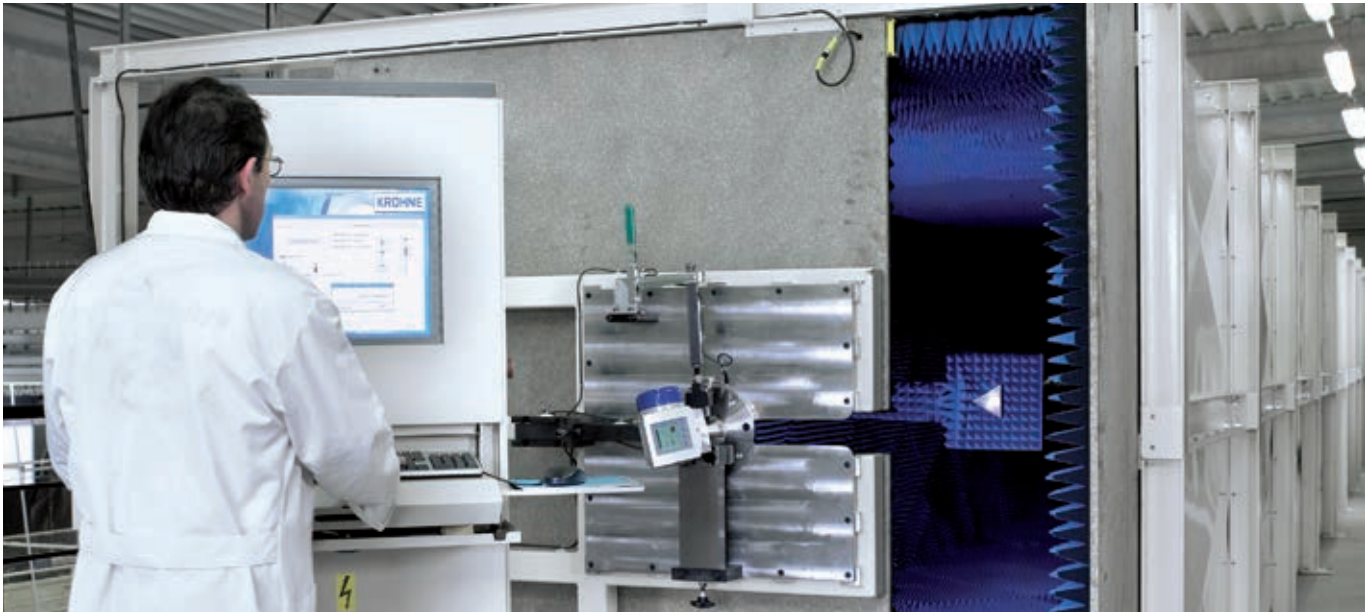

Stretch for calibration of FMCW level transmitters

Volumetric piston prover

This goes for small as well as for very large sizes: KROHNE operates the world's most precise volumetric calibration rig for flowmeters up to DN 3000/120" with a certified accuracy of 0.013 %. The reference vessel is a 44 m/144 ft high tank containing almost ½ million litres/132,000 gal (US) of water which allows for a maximum flow rate of 30,000 m³/h/7,925,000 gal (US)/h.

Certified technology for fiscal & custody transfer applications

Our meters can be calibrated and certified according to various standards such as OIML, API, Measuring Instruments Directive (MI-001, 002, 004, 005), GOST, etc. The standards we use for calibration are ISO/IEC 17025 accredited and traceable to international or national standards. Regular inspections by national metrology institutes, round robin tests and alignments with national and international metrological standards according to ISO 9000 and EN 45000 guarantee the quality and comparability of our calibration rigs. Staff performing the calibrations are trained and given regular re-trainings to ensure quality and continuity.



KROHNE – Process instrumentation and Measurement solutions

- Flow
- Level
- Temperature
- Pressure
- Process analysis
- Services



Contact

Head office
KROHNE Messtechnik GmbH
Ludwig-Krohne-Str. 5
47058 Duisburg
Germany
Tel.: +49 203 301 0
Fax: +49 203 301 103 89
info@krohne.com

Global companies and representatives
The current list of all
KROHNE contacts and
addresses can be found at:
www.krohne.com